



SunPower E-Series: E20-327

SunPower® Residential DC Panel

SunPower E-Series panels combine high efficiency with the strongest durability and warranty available in the market today, resulting in more long-term energy and savings.^{1,2}



Maximum Power. Minimalist Design.

High efficiency means more power and savings per available space. With fewer panels required, less is truly more.



More Lifetime Energy and Savings

Designed to deliver 45% more energy in the same space over 25 years in real-world conditions like partial shade and high temperatures.²

Fundamentally Different. And Better.



The SunPower Maxeon® Solar Cell

- Enables high efficiency panels²
- Unmatched reliability³
- Patented solid metal foundation prevents breakage and corrosion



As Sustainable As Its Energy

- Ranked #1 in Silicon Valley Toxics Coalition 2015 Solar Scorecard⁴
- First solar panels to achieve Cradle Certified™ Silver recognition⁵
- Contributes to more LEED categories than conventional panels⁶

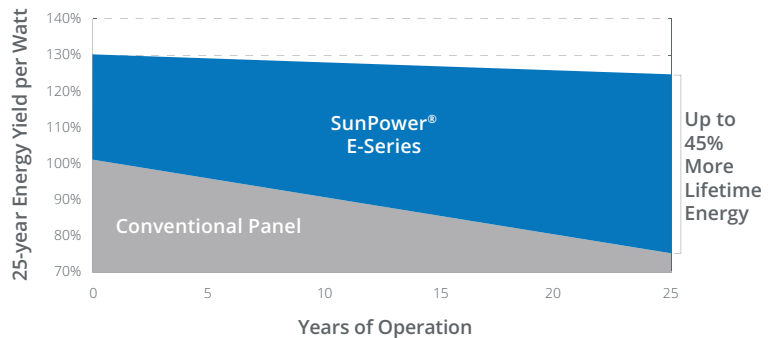

Best Reliability, Best Warranty

With more than 25 million panels deployed around the world, SunPower technology is proven to last. That's why we stand behind our panel with the industry's best 25-year Combined Power and Product Warranty, including the highest Power Warranty in solar.

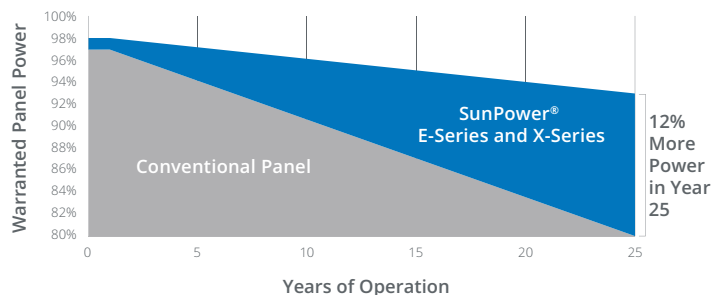

E-Series: E20-327 SunPower® Residential DC Panel

Electrical Data		
	SPR-E20-327	SPR-E19-320
Nominal Power (P _{nom}) ⁷	327 W	320 W
Power Tolerance	+5/0%	+5/0%
Panel Efficiency	20.1%	19.6%
Rated Voltage (V _{mpp})	54.7 V	54.7 V
Rated Current (I _{mpp})	5.98 A	5.86 A
Open-Circuit Voltage (V _{oc})	64.9 V	64.8 V
Short-Circuit Current (I _{sc})	6.46 A	6.24 A
Max. System Voltage	1000 V IEC & 600 V UL	
Maximum Series Fuse	15 A	
Power Temp Coef.	-0.35% / °C	
Voltage Temp Coef.	-176.6 mV / °C	
Current Temp Coef.	2.6 mA / °C	

Tests And Certifications	
Standard Tests ⁸	IEC 61215, IEC 61730, UL1703 (Type 2 Fire Rating)
Quality Management Certs	ISO 9001:2015, ISO 14001:2015
EHS Compliance	RoHS, OHSAS 18001:2007, lead free, REACH SVHC-163
Sustainability	Cradle to Cradle Certified™ Silver. "Declare." listed.
Ammonia Test	IEC 62716
Desert Test	10.1109/PVSC.2013.6744437
Salt Spray Test	IEC 61701 (maximum severity)
PID Test	1000 V: IEC 62804, PVEL 600 hr duration
Available Listings	TUV, UL, MCS, FSEC, CEC

1 SunPower 327 W compared to a Conventional Panel on same-sized arrays (260 W, 16% efficient, approx. 1.6 m²), 4% more energy per watt (based on PVsyst pan files), 0.75%/yr slower degradation (Campeau, Z. et al. "SunPower Module Degradation Rate," SunPower white paper, 2013).

2 Based on search of datasheet values from websites of top 10 manufacturers per IHS, as of January 2017.

3 #1 rank in "Fraunhofer PV Durability Initiative for Solar Modules: Part 3". PVTech Power Magazine, 2015. Campeau, Z. et al. "SunPower Module Degradation Rate," SunPower white paper, 2013.

4 SunPower is rated #1 on Silicon Valley Toxics Coalition's Solar Scorecard.

5 Cradle to Cradle Certified is a multi-attribute certification program that assesses products and materials for safety to human and environmental health, design for future use cycles, and sustainable manufacturing.

6 X-Series and E-Series panels additionally contribute to LEED Materials and Resources credit categories.

7 Standard Test Conditions (1000 W/m² irradiance, AM 1.5, 25° C). NREL calibration Standard: SOMS current, LACCS FF and Voltage.

8 Type 2 fire rating per UL1703:2013, Class C fire rating per UL1703:2002.

9 AS/NZS4040.2 Static strength test regime, AS/NZS1170.2 Structural Design Actions – Wind Actions.

See www.sunpowercorp.com.au/company for more reference information. Specifications included in this datasheet are subject to change without notice.

©2018 SunPower Corporation. All rights reserved. SUNPOWER, the SUNPOWER logo and MAXEON are trademarks or registered trademarks of SunPower Corporation. Cradle to Cradle Certified™ is a certification mark licensed by the Cradle to Cradle Products Innovation Institute.

☎ 1 800 786 769

sunpower.com.au

Operating Condition And Mechanical Data	
Temperature	-40° C to +85° C
Impact Resistance	25 mm diameter hail at 23 m/s
Appearance	Class A
Solar Cells	96 Monocrystalline Maxeon Gen II
Tempered Glass	High-transmission tempered anti-reflective
Junction Box	IP-65, Multi-Contact (MC4)
Weight	18,6 kg
Max. Load	G5 Frame: Wind: 3000 Pa, 305 kg/m ² front & back Snow: 6000 Pa, 611 kg/m ² front
	G3 Frame: Cyclonic Wind: 7500 Pa, 764 kg/m ² ⁹ Snow: 5400 Pa, 550 kg/m ² front
Frame	Class 1 black anodised (highest AAMA rating)

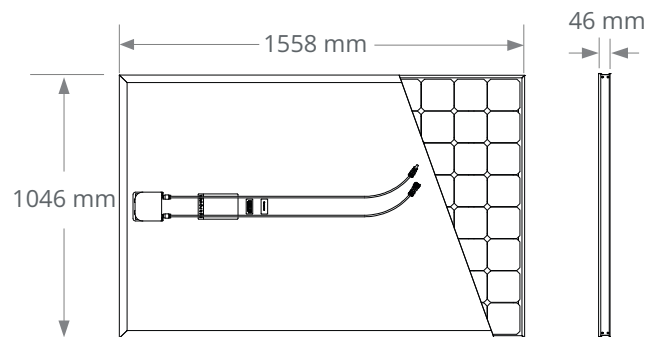

G5 FRAME PROFILE
InvisiMount™ Compatible

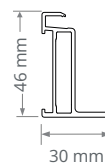

G3 FRAME PROFILE
Not InvisiMount Compatible

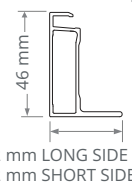

G5 frames have no mounting holes. Please read the safety and installation guide.

SUNPOWER®

527774 REV A / A4_AU